



PhoneStat G4

Telecommunications cost
management

MSI 
TeleSolutions

The software that manages your communications data

PhoneStat G4

The comprehensive and careful management of communications infrastructures is extremely important to the success of a company nowadays.

It is essential for your staff to be accessible by telephone for your company to provide a high-quality service. PhoneStat G4 is a new generation of call data software.

The software combines traditional telecommunications cost management with analysis of calls. Telephony costs alone are no longer the single decisive factor. It is becoming increasingly important to obtain an overview of the volume of telecommunications and accessibility in the company.

PhoneStat G4 is the ideal tool for complete controlling of your communications traffic: Irrespective of whether you want to analyse call and data costs,

- Plug & Play installation
- Central reporting for homogeneous and mixed telecommunications networks
- Open interfaces for data import and export
- Report generator
- Multiple output formats



invoice items externally or manage multiple sites centrally. The user-friendly software fits seamlessly into your company's existing IT environment.

Allocate and recharge communications costs internally

A major issue for precise controlling is the allocation of communications costs within the company to the individual cost or profit centres. PhoneStat G4 adapts to the organisational structure of your company and allocates the call costs incurred:

- Organisation administration with 3 levels (5 levels with Prof/Web add-on)
- Filter by private, work, incoming and outgoing calls by time/amount thresholds and much more.
- Billing with variable factors and supplements, separated into work and private

Optimise communications volume

PhoneStat G4

Analyse communications structures

Analysis is the first step on the road to optimisation. The goal is to organise your employees' efforts more efficiently.

The software helps you clarify the important questions:

- „What is the average time a caller has to wait?“
- „How many calls does a department handle in a day?“
- „When are the peak times?“

PhoneStat G4 helps you answer these questions for good.

- Display unanswered calls and response times of the hotline
- Show peak times and intensity of communications in Sales and Service
- Analysis of employee capacity utilisation during the day

By permanently monitoring communications processes, problems can quickly

be identified and appropriate optimisation steps can be taken.

Integrated tariff tables

PhoneStat G4 has integrated tariff tables.*

- Call costs are automatically calculated correctly.
- Easy tariff updates via Internet subscription
- Variable recharge factors can be defined

Generate revenue

With PhoneStat G4 you can record communications costs and invoice them externally.

- Pass on telephony costs to customers and clients
- Billing for sub-tenants
- Billing for employees' private calls
- Recharge communications costs with supplements

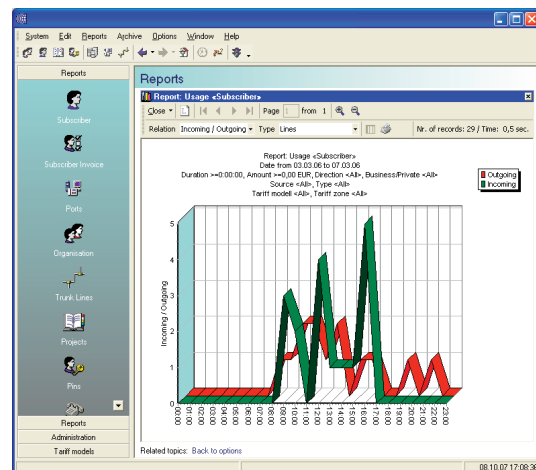
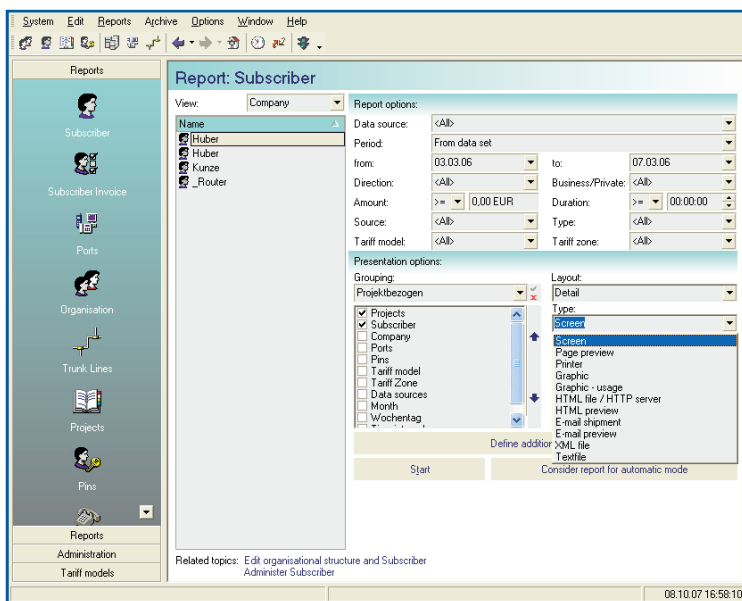

Communications controlling - easy to use

PhoneStat G4

Easy to use

Working with PhoneStat G4 is simple and convenient.

- Easy to integrate into your IT environment
- Comprehensive online help
- Multiple display options for the reports

Convenient to use

The Prof/Web add-on makes using PhoneStat G4 even more convenient. Pre-defined and automated reports mean less work for you (see Prof/Web add-on).

Adapts to your company's requirements

PhoneStat G4 is easy to customise to requirements in your company.

- User rights can be defined in groups
- User rights can be assigned and administered in great detail
- Select the menu options „read only“ and „read/write“ for individual user groups
- Data protection by means of task-driven definable access rights to the system and variable hiding of telephone numbers

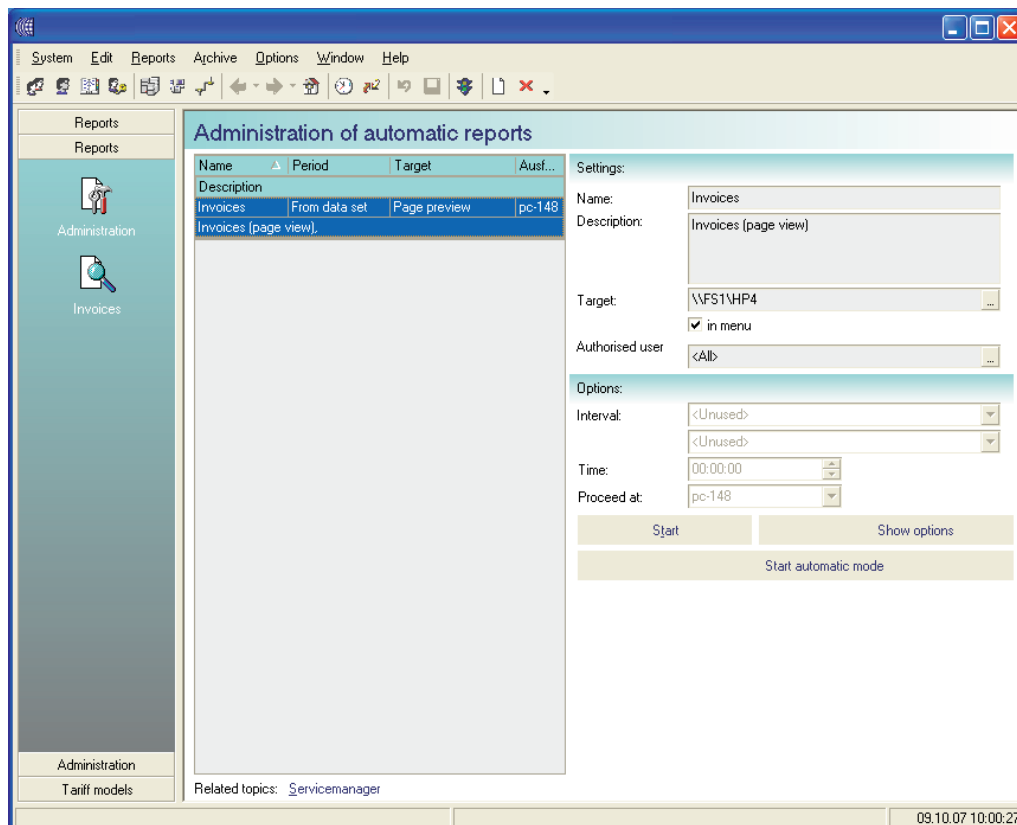

Optional add-ons for more convenience

PhoneStat G4

Prof/Web optional add-on module

Your reports are automated by a report generator. Use the time-saving report functions. The Professional add-on allows PhoneStat to be adapted to your organisation in five levels.

- Comprehensive report layout options
- As many layouts as you like can be saved
- Define and save reports
- Define the report interval
- Report generator can generate reports automatically
- Complex organisational administration with 5 levels
- Output formats (automated): HTML file, XML file

HTML preview

Report: «Subscriber»
Date from 01.01.06 to 31.12.06
Duration >=0:00:00, Amount >=0,00 EUR, Direction Outgoing, Business/Private "All"
Source "All", Type "All"

Kunze
Extension 28

Source port	Start	Duration	Target port	Amount orig	Gross amount	VAT	Pin	Privat	Busin	Inco	Outg
28	03.03.06 09:5	2:05:0621199*****		0,49 EUR	0,57 EUR	16,00%					+
28	03.03.06 11:1	12:49*****		2,13 EUR	2,47 EUR	16,00%					+
28	03.03.06 13:2	8:21 03633148*****		1,47 EUR	1,71 EUR	16,00%					+
28	03.03.06 15:2	3:02 03626707*****		0,86 EUR	0,77 EUR	16,00%					+
28	04.03.06 12:2	7:24 0526290*****		1,31 EUR	1,52 EUR	16,00%					+
28	05.03.06 21:0	0:55 0621199*****		0,16 EUR	0,19 EUR	16,00%					+
28	06.03.06 10:1	11:51 8584*****		1,97 EUR	2,29 EUR	16,00%					+
28	07.03.06 08:4	4:31 05*****		0,82 EUR	0,95 EUR	16,00%					+
28	07.03.06 11:2	1:35 0621199*****		0,33 EUR	0,38 EUR	16,00%					+
28	07.03.06 13:0	15:00 075063*****		2,48 EUR	2,85 EUR	16,00%					+
28	07.03.06 16:2	2:35 0621199*****		0,49 EUR	0,57 EUR	16,00%					+
28	07.03.06 19:1	9:08 0033450*****		4,22 EUR	4,90 EUR	16,00%					+
Total Netto:					16,51 EUR						
VAT (16,00%):					2,64 EUR						
Total:				1:19:12		19,15 EUR		6	6	0	12

- Output destinations: send by e-mail, HTTP server
- No printing costs and reduced management costs due to output by e-mail and in HTML/XML documents

Client/server add-on

The Client/server add-on allows you to operate the application in client-server mode. This is required if PhoneStat G4 is to be used on multiple workstations.

- Database server software supplied
- Data prepared on the server via IP protocol without network shares

Report options:

Data source: <All>

Period: Last year

from: 01.01.06 to: 31.12.06

Direction: <All> Business/Private: <All>

Amount: >= 0,00 EUR Duration: >= 00:00:00

Source: <All> Type: <All>

Tariff model: <All> Tariff zone: <All>

Presentation options:

Grouping: Art 1

Layout: Layout 1

Type: HTML file / HTTP server

Target: X:\G4_EN\HTML.htm

Show Details

Open report in own window

Save reports

Define additional mark-ups

Start Consider report for automatic mode

Fit for any scenario

PhoneStat G4

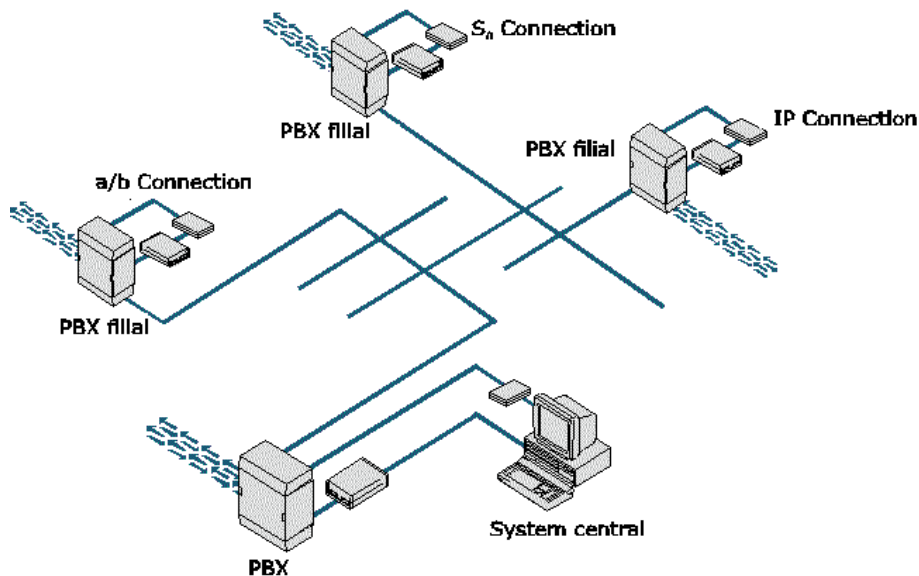

Features

- User-friendly interface with comprehensive help
- The standard tariff models for all relevant telephony providers are integrated into the basic configuration*.
- The annual subscription for tariff tables guarantees that tariff data is updated
- Basic package includes 30 extension licences
- Reports by extension, subscriber, organisational unit, project, tariff model, switched line, PIN and called numbers
- Meaningful and clear reports with graph function
- Report layouts can be saved
- Output as preview on screen or to the printer
- Data export as TXT file (optionally as HTML or XML file)
- Report generator (optional)
- Can be connected to Siemens HiPath, Alcatel OmniPCX as well as to various other telecommunications systems (please ask).
- Simply installation by means of connection via LAN interface or with external buffer (V.24).
- Flexible composition of the individual modules

* At present tariff tables are available for the following countries: Germany, Austria, Switzerland, Italy, the Netherlands.

Technical requirements

PhoneStat G4

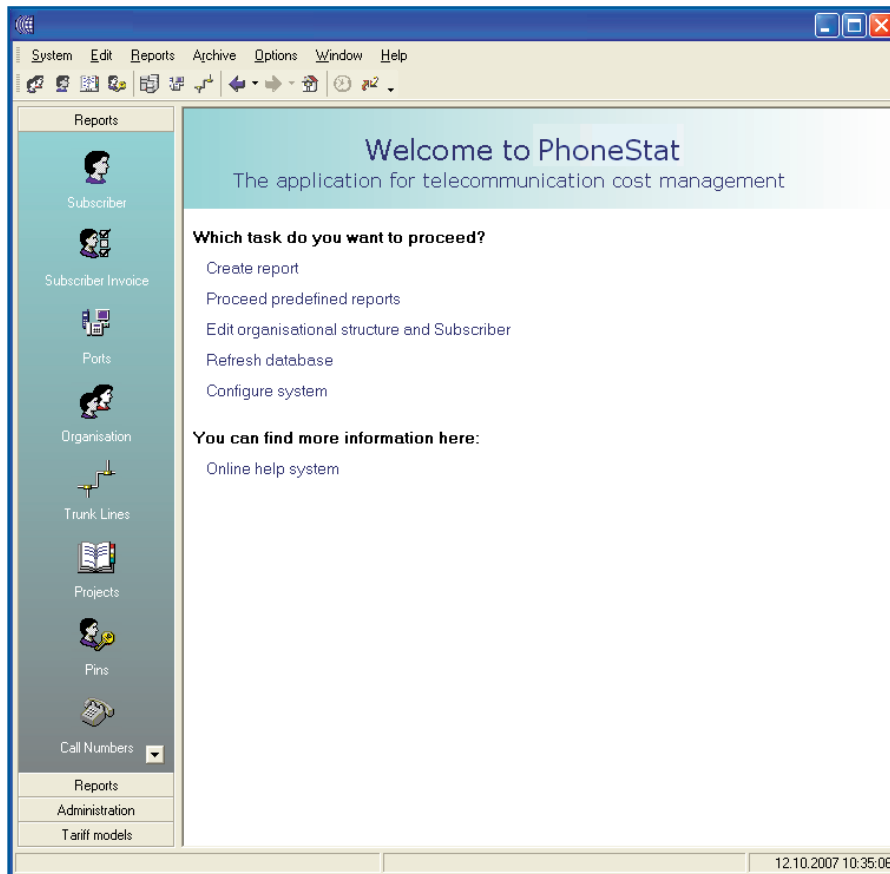

PC system requirements

- Windows XP Professional
- Windows 2000 Professional/Server
- Windows Server 2003
- Windows Vista Business/Ultimate
- PC as specified for the operating system
- Network card
- Min. RAM 512 MB
- Min. RAM 1024 MB for Vista
- Processor speed min. 1GHz
- CD ROM drive or compatible
- COM port for controller connection (i.e. with buffer)
- USB port for LAN/file connection

We have also developed the product HospiX Entry to meet the specific needs of hotels and guesthouses.

PhoneStat G4

MSI Solutions GmbH
Geisenhausenerstr.17
81379 München

Tel.: +49 (89) 74 85 64-0
Fax: +49 (89) 74 85 64-33

Internet: www.msi-telesolutions.com
E-Mail: info@msi-telesolutions.com

